

Diesel Exhaust Thermometers, with Capillary Line

LTAf

Crimped-on ring case stainless steel

Diesel exhaust thermometers are especially applied for measurement of exhaust and cooling water temperatures in diesel engines.

They are particularly designed for these high mechanical and technical loads, among others through the "stem in jacket version" and a standard case filling with a highly viscous silicone oil. For a longer service life, diesel exhaust thermometers should always be applied in combination with a thermowell.

Standard Versions

Information on selection and metrological features (temperature-resistance, among others) and temperature ranges / smallest subdivision / error limits can be found in model overview 8000.

Measuring Unit

With nitrogen filling
(inert gas, physiologically safe)

Accuracy (EN 13 190)

Class 1

Case

With polished crimped-on ring, 1.4301 (304 stainless steel)

Case Protection Type (EN 60 529 / IEC 529)

IP 65

Case Filling

Silicone oil

Nominal Case Sizes

63, 80, 100 mm (2½", 3", 4")

Case Configuration

Connection temperature
sensor (stem):

capillary line

Capillary line position: vertical bottom position,
optional: centre back position (**rm**),
see page 2

Mounting device:

for bottom capillary line position:
back flange for surface mounting (**Rh**) or
mounting device for gauge holder
bracket (**Mgh**)

for centre back capillary
line position (**rm**):
u-clamp for panel mounting (**BFr**)
back flange for surface mounting (**Rh**)

Capillary line (standard) 1 m stainless steel Ø 2 mm, with buckle
protection tubes at both ends
capillary line length L_{FL} selectable from
1 m to 15 m (> 15 m upon request)

Temperature Ranges

0 – 120 °C
50 – 650 °C

Temperature Sensor (Stem)

Made of stainless steel 1.4571 (316 L),
max. static operating pressure: 25 bar
Stem models (jacket version): A5.5, A1.5 or A3.5
Stem-Ø dF: 10, 12 or 13 mm
Stem length (standard): 150, 200, 250, 300 or 400 mm
Compression fitting
for stem model A5.5: steel galvanised



Window

Instrument glass

Movement

Brass/German silver

Dial

Aluminium white, scaling black

Pointer

Aluminium black

Indication Adjustment (± 6%)

From the outside via a screw

Ordering Information, Standard Temperature Ranges, Options

See page 4

Special Versions and further Options among others

- Other stem lengths and connection threads upon request
- Versions for extreme loads
- Capillary line $F_{FL} > 15$ m upon request
- Other temperature ranges and/or special scales, e.g. dual scale °C/°F, coloured fields or ranges, dial inscriptions, etc.
- Case parts stainless steel 316 L (1.4404) upon request
- Position of the connection radial at 3 o'clock, 9 o'clock, 12 o'clock, others upon request or other than vertical installation (90°)
- GOST-version for Russia, Ukraine, Kazakhstan

Thermowells

See DS 8.8110 ff.



Sales and Export South, West, North

ARMATURENBau GmbH

Manometerstraße 5 • D-46487 Wesel-Ginderich
Tel.: +49 (0)28 03/91 30-0 • Fax: +49 (0)28 03/10 35
armaturenba.com • mail@armaturenba.com

LEYRO INSTRUMENTS SL
Avda. Somosierra
2428703 San Sebastián de los Reyes
Madrid
Tel: +34 912 835 502
info@leyro.net
www.leyroinstruments.com

leyro

Vertical Bottom Capillary Line Position

Mounting device for gauge holder brackets¹⁾
code letters **Mgh**

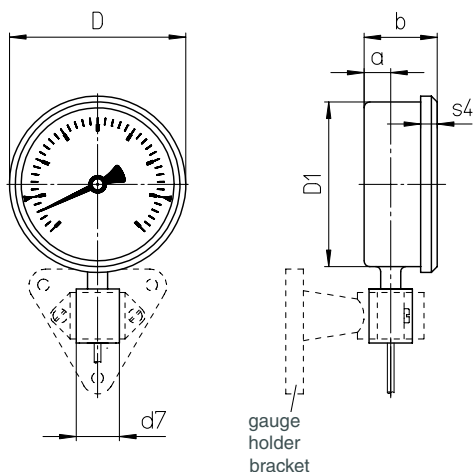

Back flange for surface mounting
code letters **Rh**

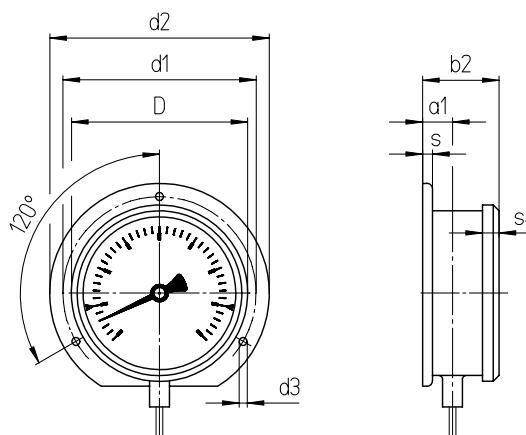

Centre Back Capillary Line Position

U-clamp for panel mounting
code letters **rmBFr**

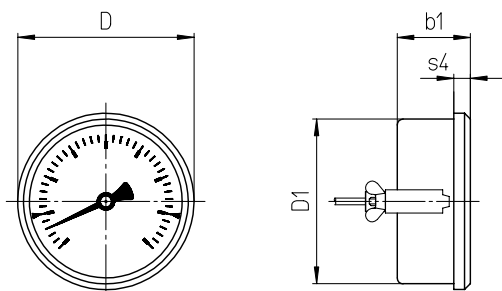

Back flange for surface mounting (except NCS 80)
code letters **rmRh**

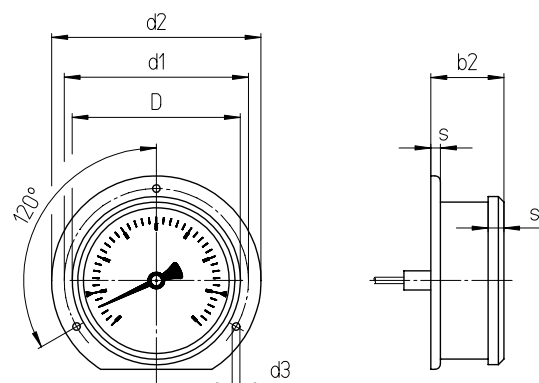

Dimensional Data (mm / inches) and Weights (kg / lb)

NCS	a	a1	b	b1	b2	D	D1	d1	d2	d3	d7	s	s4	approx. Weight ²⁾ TAF
63	12	15	39	39	42	67	62	75	85	3.6	26	5	8	0.45
2½"	.47	.59	1.54	1.54	1.65	2.63	2.44	2.95	3.35	.14	1.02	.20	.31	0.99
80	15	18	42	42	45	86	79	95	110	4.8	26	5	8	0.6
3"	.59	.71	1.65	1.65	1.77	3.39	3.11	3.74	4.33	.19	1.02	.20	.31	1.32
100	15	18.5	43	43	46.5	106	99	116	112	4.8	26	6	10	0.78
4"	.59	.73	1.70	1.70	1.83	4.17	3.90	4.57	4.41	.19	1.02	.24	.40	1.72

¹⁾ Details on gauge holder brackets can be found in the data sheets on accessories of our catalogue-heading 8.

²⁾ The indications serve as example and relate to versions with mounting device for Mgh and stem A1.5, Ø 10 mm (0.4"), length 200 mm (8").

Stem Models

Process connection: without screw fitting, plain stem

Stem model: A1.5
Form according to DIN 13 190: Form 1
Stem material: 1.4571
Stem-Ø dF: 10, 12, 13
Order length L (standard length): 150, 200, 250, 300, 350, 400

Data sheet (suitable thermowell models): 8.8141 (SK2)

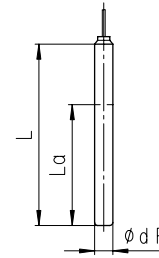

Process connection: Union nut

Stem model: A3.5
Form according to DIN 13 190: Form 5
Stem material: 1.4571
Stem-Ø dF: 10, 12, 13
Screw fitting material: 1.4571
Order length L (standard length): 150, 200, 250, 300, 350, 400

Data sheet (suitable thermowell models): 8.8112 (SF4F), 8.8113 (SF4.1F), 8.8131 (SF9)

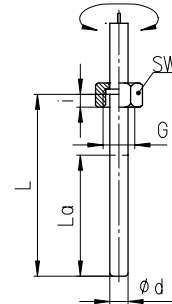

Thread (dimensions in mm):

G	SW	i
G ½	27	10
G ¾	32	12
M 20x1.5	27	10
M 27x2	32	12

Process connection: Male thread / Compression fitting

Stem model: A5.5
Form according to DIN 13 190: Form 2
Stem material: 1.4571
Stem-Ø dF: 10, 12, 13
Screw fitting material: steel galvanised
Order length L (standard length): 150, 200, 250, 300, 350, 400

Data sheet (suitable thermowell models): 8.8110 (SF4), 8.8112 (SF4F), 8.8121 (SF6+SF7)

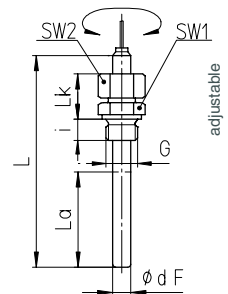

Thread (dimensions in mm):

G	SW1	i	Lk
G ½ B	27	14	35
G ¾ B	32	16	37
M 20x1.5	27	14	35
M 27x2	32	16	37

Stem-Ø	SW2
10	19
12	22
13	24

Minimum Stem Length, Active Length and Maximum Realisable Stem Length

Stem model:	Capillary line including stem ≤ 5 m		Capillary line > 5 m	
	La	Lmin	La	Lmin
A1.5	80	150	120	175
A3.5	80	150	120	150
A5.5	80	150	120	175
others	upon request			

The minimum length **Lmin** of the stem is the smallest possible stem length.

The active length **La** of the stem (temperature-sensitive part) has to immerse completely into the medium, in order to obtain a measuring result that corresponds to the accuracy class.

The maximum realisable stem length is 400 mm.

Basic Model: Diesel Exhaust Thermometers with Capillary Line		TAF
Case filling:	silicone oil	G
Nominal case size:	case-Ø 63, 80, 100 mm (2½", 3", 4")	63, 80, 100
Stem position / Case configuration:	vertical bottom position, mounting device for gauge holder bracket	Mgh
	vertical bottom position, back flange for surface mounting	Rh
	centre back position, back flange for surface mounting	rmRh
	centre back position, u-clamp	rmBFr
Temperature ranges:	0 – 120 °C	0 – 120 °C
	50 – 650 °C	
Stem in jacket version:	A1.5	A1.5
	A3.5	A3.5
	A5.5	A5.5
Stem-Ø dF:	10, 12 or 13 mm	dF 10, 12, 13
Stem length:	L 150, 200, 250, 300, 350, 400	e.g. L = 150 mm
Capillary line length:	L _{FL} ≥ 1 to 15 m	L _{FL} = 3 m
Process connection:	see page 3	e.g. G ½ B
Options:	red mark on dial	<i>(order at present still in cleartext)</i>
	plastic clip red or green, external on crimped-on ring for NCS 80 and 100	
	window tempered safety glass for NCS 80 and 100	
	movement stainless steel	
	case polished	
	compression fitting stainless steel	
	protective hose for capillary line flexible armour made of stainless steel	
	Version: German Lloyd or Russian Sea Register	
	Typ TAF 63, 80, 100 copy of the certificate upon request	
	measuring point marking stainless steel plate 12 mm x 55 mm (0.47" x 2.17") with wire mounting or sticker on case coverage	

Example: TAF 100, bottom Mgh, 0 – 120 °C, A3.5, dF 8, L = 150 mm, L_{FL} = 3 m, G ½

Special Versions: Please describe your requirements in cleartext